

Transport, Installation, Commissioning

C100

C200

Note on applicability

Illustrations in this publication may deviate from the product supplied. Errors and omissions due to technical progress expected.

A word on copyright

This document is protected by copyright and was originally compiled in German. The duplication and distribution of this document or parts thereof is prohibited without prior consent of the copyright owner, and any violators will be prosecuted. All rights, including the right to translate, are reserved.

© Copyright by INDEX-Werke GmbH & Co. KG

Table of Contents	3
Safety precautions.....	5
Information on transport, installation, commissioning	5
General hazards during on-site transport	5
Dimensions and masses.....	6
Transporting and lifting aids.....	6
Transport gear, ropes.....	6
Preparations	7
Appropriate transporting and lifting aids	7
Space requirements	8
Subsoil, foundation	8
Environmental conditions	8
Power supply	9
Compressed-air supply	9
Main circuit breaker.....	9
External data transfer.....	10
Pressure accumulator.....	10
Operating material to be provided.....	10
Pumps and tanks.....	11
Chip removal	11
Disposal of used operating materials.....	11
Observing the ground and waste water regulations.....	11
Transport.....	12
Transport C100	12
Transport chart	12
Transport C200	13
Transport chart	13
Delivery.....	14
Machine	14
Pressure accumulator	14
Other separate units.....	14
Transport gear	14
Unloading the Machine With a Crane	16
C100	17
Transport locks	18
C200.....	19
Transport locks	20
C200 with WHU.....	21
Transport locks	23

Transporting with Forklift	24
C100	24
C200	25
Transporting with casters	26
C100	27
C200	28
Lowering the Machine at the Installation Site	29
... with a crane or mobile crane	29
... with hydraulic jacks (Figure).....	29
Installing the control cabinet.....	31
Unloading and transporting of separate units	33
Unpack the accessories and check them for completeness	33
Installation	34
Electrical connection	34
Important notes.....	34
Installing the machine	35
Level the machine.....	36
Installation and leveling of expansion stages and accessories.....	37
Commissioning.....	38
Cleaning the machine	38
Check the operating fluid levels and replenish, if necessary.....	38
Pressure accumulator.....	38
Removing the Transport Locks.....	39
Attaching Filling/Breathing Filter.....	40
Data loss due to prolonged downtime	40
Switching on the machine.....	40
Relocation	41
Only for machines equipped with chip conveyor	41
Only for Machines Equipped With Bar Feeder or Bar Loading Magazine.....	41

Safety precautions

Information on transport, installation, commissioning



If the door to the work area is open, the door safety switch will remain open after disconnecting the power supply line.



Transport locks can be identified by their red color.

Failure to follow proper procedures for transport, installation and start-up is prone to cause accidents and may induce damages to or malfunctions of the machine for which **INDEX** rejects any liability or warranty.

Prior to delivery of the machine, the procedures for unloading, transporting to the installation site, installation, and start-up must be carefully planned while absolutely observing the cautions below in this document.

Associated transport instructions exist for separate units such as chip conveyor, bar feeder, bar loading magazine and similar devices. These special transport instructions must also be followed without fail.

General hazards during on-site transport

Machines must be transported by authorized and qualified personnel only.

Act responsibly when transporting the system and always consider the consequences. Avoid dangerous and risky actions.

Slopes and gradients (driveways, ramps, etc.) are particularly dangerous. Use extra care if such passage-ways cannot be avoided.

Ensure secure and proper seating of the cargo. If necessary, use additional fixtures to ensure that the cargo is not able to slip.

The transport vehicles must be able to produce sufficient traction and braking forces for safe transport.

Dimensions and masses

The machine and control cabinet masses are indicated on the respective machine installation plan in Chapter "Working Documents".

The masses of optional separate units, such as chip conveyor, bar feeder, bar loading magazine and similar devices, can be found either in the specific transport instructions for these options or accessories, or in the corresponding machine installation plan in Chapter "Working Documents".

Transporting and lifting aids

For lifting and transporting the individual units, only lifting and transporting aids having sufficient capacity and loading platform must be used.

Transport gear, ropes

When lifting the machine by means of a crane, use only the supplied transport gear. This also applies to certain separate units such as bar feeder and bar loading magazine.

For all other separate units, dedicated transport gear is not supplied for lifting with a crane.

Consider the prescribed load capacity and length when selecting your own transport gear or ropes/slings.

When selecting and applying the transport gears or ropes/slings, follow the relevant information in this document such as:

- Unloading the machine with a crane.
- Unloading and transporting of separate units

Preparations

This section is addressed to the persons responsible for the installation and their staff.

The information provided here allows you to prepare the installation site and its surroundings such that the machine, when delivered, can be installed and put into operation immediately.

Be sure to carefully plan the delivery, unloading, and transporting of the machine from the unloading site to the installation site.

Take the size (dimensions) and masses of each unit into consideration.

Suitable transporting and lifting means must be available when the machine is delivered.

Any obstacles along the transport route from the unloading site to the installation site must be eliminated before the machine is delivered.

Check the transport route for load capacity, levelness, damaged pavement, traverse grooves, slopes, gradients, etc.

Is the width and height of entrances and gates sufficient?

If elevators are to be used, do they have sufficient capacities?

Proper planning will pay off!

Appropriate transporting and lifting aids

- Crane
- Truck-mounted crane
- Forklift
- Transport trolley
- Transport casters
- Hydraulic jacks
- Forklift truck (only for separate units; not suitable for machines).

Space requirements

The following must be ensured:

- Sufficient free space around the machine.
- Sufficient movement space for the operator.
- Sufficient space for maintenance and repair.
- It must be possible to open all doors of the machine completely.
- Space for placing blank and workpiece pallets, workpiece containers, chip trolleys, tool trolleys, etc.

Use the machine installation plan in Chapter “Working Documents” to determine the required space.

Chapter “Working Documents” also includes specific installation plans for additional equipment such as bar feeders, bar loading magazines, etc.

Subsoil, foundation

A special foundation is not necessary. Only the load capacity and strength of the floor must be suitable for the machine weight based on constructional aspects.

There must be no expansion joints in the area of the machine footprint.

The machine can be anchored in the foundation. For the distances between the anchoring holes, see the machine installation plan in Chapter “Working Documents”.

Bar guides, bar feeders, and bar loading magazines must generally be anchored in the foundation (for information, see the associated operating instructions and the machine installation plan in Chapter “Working Documents”).

If a bar feeder or bar loading magazine is used, **INDEX** also recommends anchoring the machine in the foundation.

Environmental conditions

See Environmental Conditions in the document “Safety precautions”



If the actual conditions at the installation site differ from these specifications, be sure to contact INDEX or an INDEX representative.

Power supply



The power supply cord to the machine should be as short as possible. Use a sufficient wire size.

The power supplies for the programmable logic controller (PLC) and the numerical control (NC) require stable mains conditions, i.e., the max. allowed operating voltage fluctuations are +10% or -10%.

The mains line must comply with the regulations of the local electricity supplier and the IEEE directives. For further information, see the machine installation plan in Chapter "Working Documents".



The locally valid guide lines and regulations must be taken into consideration.

Compressed-air supply



Observe the max. allowed connection pressure for the machine. See the pneumatic diagram in Chapter "Working Documents".

Machines equipped with pneumatically actuated components require a compressed-air supply with the following capacity:

Operating pressure6-10 bar

Air demand.....depending on the machine equipment

For the air supply on the machine, see the machine installation plan in Chapter "Working Documents".

Main circuit breaker



Check that the building connection has sufficient capacity to cover the additional load to be protected. Discuss any unclear conditions with your local electricity supplier.

The main circuit breaker is not included in the delivery of the machine. It must be installed outside the machine according to DIN EN 60204-1.

If a pre-transformer is required, the main circuit breaker must be installed before the pre-transformer, i.e., on the primary side.

The loads to be protected depend on the existing operating voltage.

The values for:

- machine connection,
- operating voltage,
- main circuit breaker

are to be taken from the machine installation plan in Section "Working Documents".

External data transfer



Data lines must not be routed directly next to power lines.

For data transfer to/from external computers or storage devices, suitable metal conduits must be installed for the data lines.

Pressure accumulator

If the machine was shipped by plane, all pressure accumulators attached to the machine are depressurized.

Before start-up of the machine, all pressure accumulators must be filled with nitrogen (N₂) by a specialist. The prescribed pressures must be observed.

For the prescribed pressures, see the hydraulic diagrams in Chapter "Working Documents".

Operating material to be provided

- Hydraulic fluid ¹⁾
- Lubricating oil ¹⁾
- Approx. 1 kg of high-performance grease for chuck
- Cooling lubricant

For types of lubricating oil, hydraulic fluid, grease, and cooling lubricants as well as volumes, see "Notes on Operating Materials" in Chapter "General notes" and "Hydraulic diagrams and machine installation plan" in Chapter "Working documents".



Caution:

Be sure to use only hydraulic fluid according to ISO 4406 having a purity grade of 15/12 (10 µm absolute).

Hydraulic fluid: HLP 32; HLPD 32; VG 32.

Lubricating oil: CG 68; G68

¹⁾ The machine is delivered with a full tank.

Pumps and tanks

Changing the hydraulic fluid and cooling lubricant is part of the periodic maintenance tasks.

To fill the machine's hydraulic fluid tank with hydraulic fluid, a pump with a 10 µm fine filter (absolute) is required that may be used for this purpose only.

A simple pump is sufficient to extract the used hydraulic fluid or cooling lubricant. The same pump may be used to fill the cooling lubricant tank; however, it must be thoroughly flushed with fresh cooling lubricant.

A robust container is required for collecting the extracted fluids. Suitable containers are metal barrels of sufficient capacity and with proper labels, which can be tightly closed.

Chip removal

If the machine is equipped with a chip conveyor, a chip trolley, its height matching the chip conveyor's discharge height, is required. The chip trolley should have a device for draining the accumulating cooling lubricant so it can be returned to the cooling lubricant tank.

This will protect the environment and save cost.

Disposal of used operating materials

Decide in advance on how to dispose of used operating fluids such as hydraulic fluid, lubricating oil, and cooling lubricant in an environmentally friendly manner.

Observing the ground and waste water regulations



The locally valid guide lines and regulations must be taken into consideration.

The machine contains water-polluting substances such as water-miscible cooling lubricants and mineral oils. These substances may leak from the machine in case of adverse events.

Therefore, the machine must be installed in a place that excludes any harm by these substances to waters or ground water.

Possible preventive measures:

- Place the machine inside a tight trough.
- Seal the floor of the factory hall.

Transport

Transport C100

Transport chart

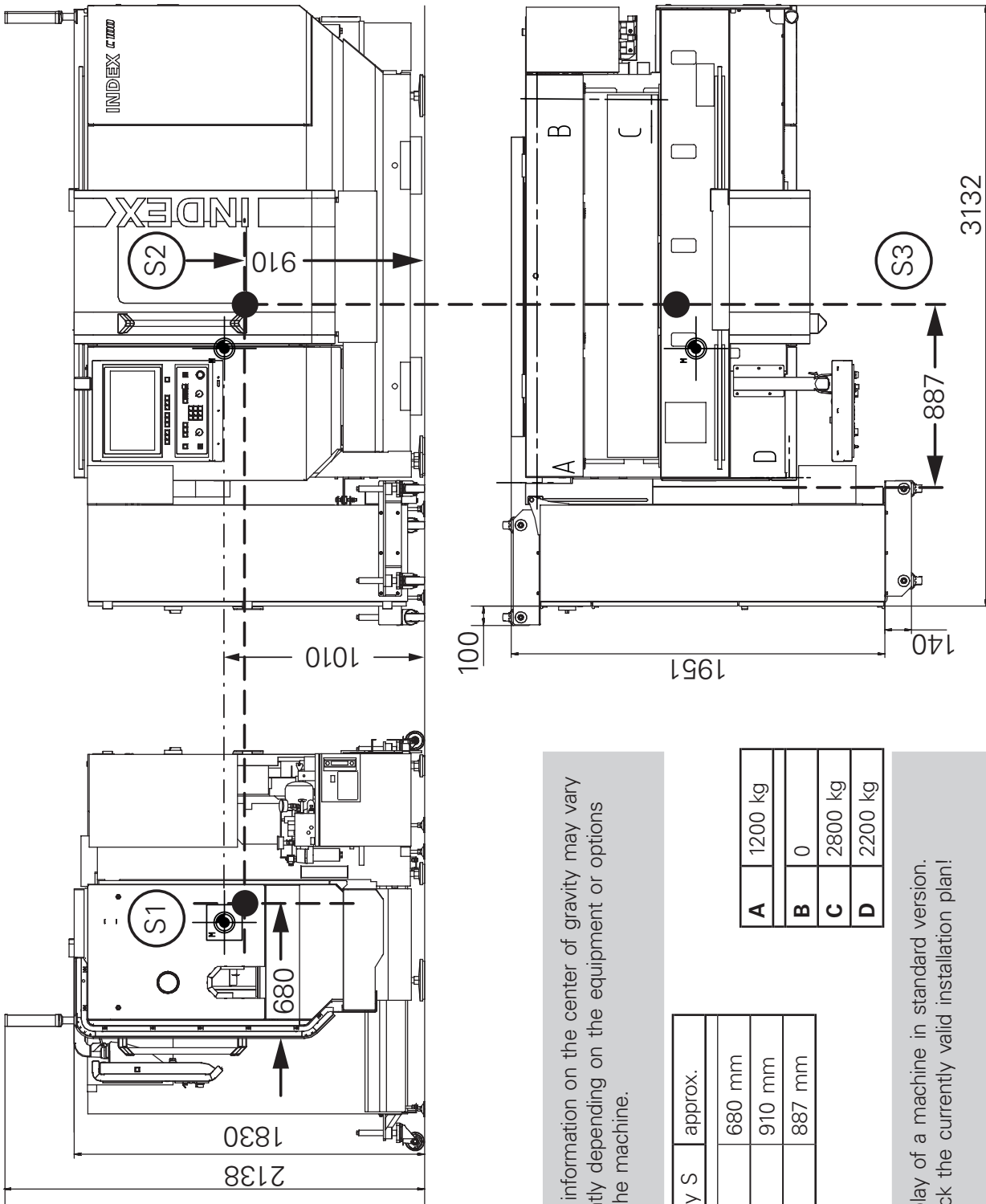

i The information on the center of gravity may vary slightly depending on the equipment or options for the machine.

Center of gravity S	approx.
S1	680 mm
S2	910 mm
S3	887 mm

A	1200 kg
B	0
C	2800 kg
D	2200 kg

i Display of a machine in standard version.
Check the currently valid installation plan!

DIE172ZZ_26.eps

Transport C200

Transport chart

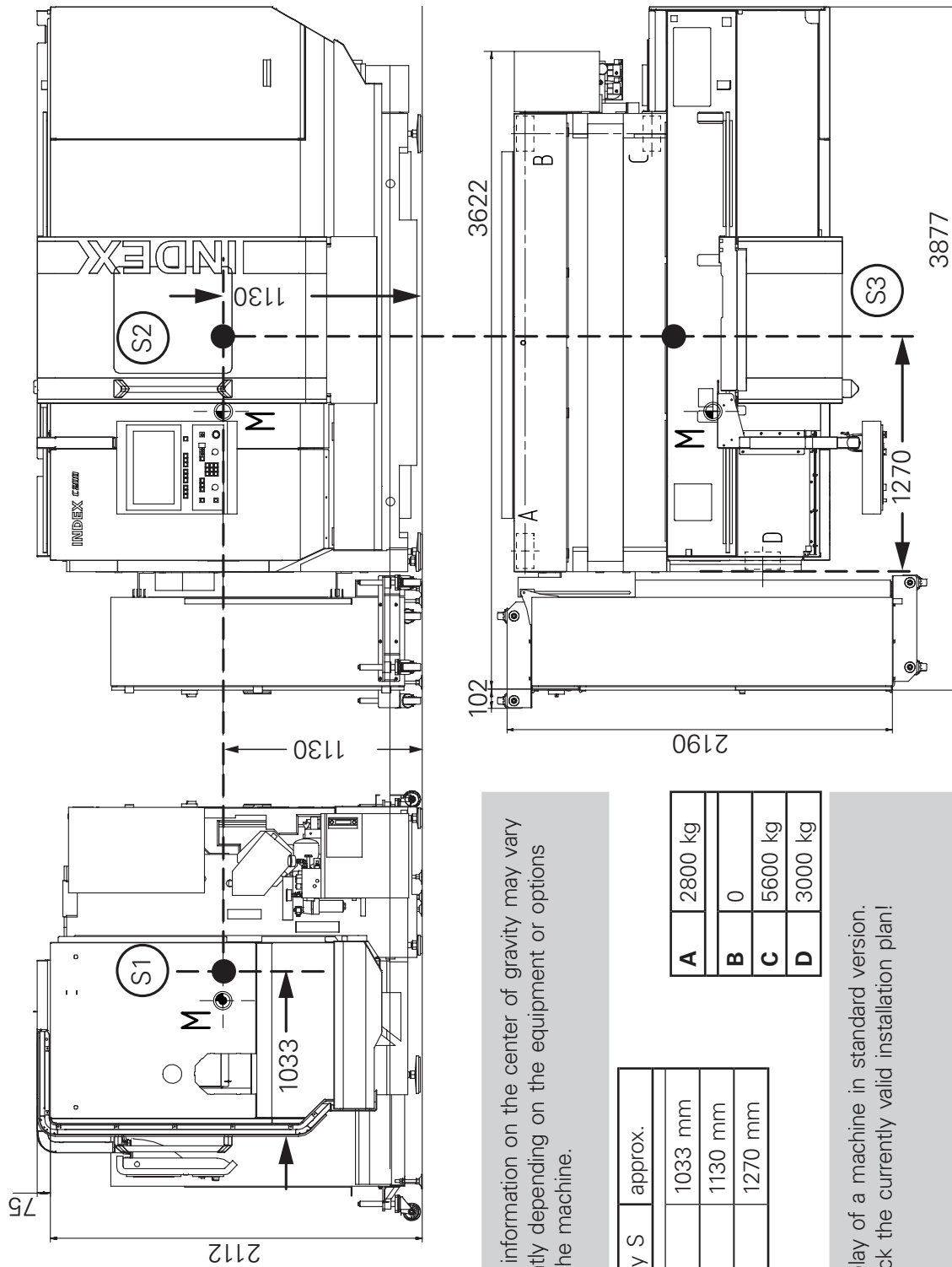

i The information on the center of gravity may vary slightly depending on the equipment or options for the machine.

Center of gravity S	approx.
S1	1033 mm
S2	1130 mm
S3	1270 mm

A	2800 kg
B	0
C	5600 kg
D	3000 kg

i Display of a machine in standard version. Check the currently valid installation plan!

DIE172ZZ_27.eps

Delivery

Machine

The machine will be delivered by a truck. It will rest either on planks or will be packed in a crate and then rest on a transport floor.

The machine will be in the following condition when delivered:

- The hydraulic fluid and lubrication oil tanks will be full.
- The cooling lubricant tank will be empty. (The machine has a chip conveyor with an integrated cooling lubricant tank or a separate coolant cleaning system. The chip conveyor and coolant cleaning system are separate units.)
- Certain moving parts on the machine, such as sliding guards and the swiveling operating panel, are secured by transport locks or were removed.
- Protruding machine parts hampering the transport have been removed.
- All blank parts of the machine were treated by spray-covering with an anti-rust agent.

Pressure accumulator

If the machine was shipped by plane, all pressure accumulators attached to the machine are depressurized.

Before start-up of the machine, all pressure accumulators must be filled with nitrogen (N₂) by a specialist. The prescribed pressures must be observed.

For the prescribed pressures, see the hydraulic diagrams in Chapter “Working Documents”.

Other separate units

Certain equipment options or accessories such as chip conveyor, bar feeder, bar loading magazine, etc. are usually separate units.

Chip conveyors usually rest on a transport base for shipping.

The bar feeder and bar loading magazine are delivered in a special shipping crate.

Loose parts such as keys, tools, and fittings, are supplied in a separate box, which may be included with a separate unit.

Transport gear

Transport gears are either packed separately or included with other units.

The transport gear is generally supplied at extra cost. Following the installation, the transport gear may be returned to **INDEX** in exchange of a credit.

Before unloading, check the machine, the enclosed accessories, and any separate units for external damages and completeness (compare bill of lading with delivery form).

Have the carrier confirm any damages or missing parts on the bill of lading or delivery form.

In case of damages during transport, it is recommended to take photos of the damages for evidence.

Inform **INDEX** or the **INDEX** representative.

Unloading the Machine With a Crane



Suspended loads!
Danger from the machine falling down.
Do not stand under suspended loads, and use only the allowable transport accessories.

Clearance of the crane hook:

Height of the unit (e.g., machine, control cabinet, etc.)

+ Transport traverse above the unit	approx. 1.2 m
+ Loading height of the truck	approx. 1.3 m
+ Lifting height	0.2 m

Remove all transport locks on the truck.

Apply the supplied transport accessories.



Use a crane with sufficient capacity. Unload the machine as close as possible to the installation site.
Short transport distances reduce the risk of accidents.

Slowly and carefully lift the machine.



Lift the machine only in a horizontal position. The center of gravity is not exactly in the center of the machine.
If necessary, set the machine down again and correct the skew by moving the hooks on the transport device as appropriate.

Lift the machine from the truck or drive the truck away from under the machine.

Move transport means (e.g., trolley) under the machine.



Select a means of transport with sufficient capacity. It must match at least the mass of the machine.
When using a trolley, the loading platform area should be larger than the base area (footprint) of the machine.

Lower machine slowly and carefully onto the trolley and move it to the installation site. Remove the transport gear beforehand.

INDEX C100

Transporting the machine

INDEX

Kunde: _____
Projekt.-Nr.: _____ Masch. Nr.: _____

Machine mass approx. 6200 kg
Transport gear approx. 250 kg

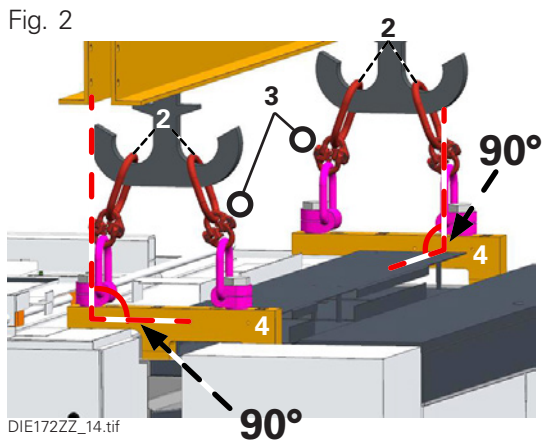

DIE172ZZ_14.tif

Caution!

Before lifting the machine, check the correct seat of the ropes/chains in the transport hooks and make sure that the hooks are engaged at the load beam (Fig.: 1 + 2) such that pulling at an angle is prevented.

If using transport ropes other than those specified herein, it is important to verify that those ropes do not contact the paneling and that the machine remains in a horizontal position (Fig. 1).

The load beam and the transport harness ropes required for the proper transport of the machine are generally supplied at a fee and can be returned to **INDEX-Werke** after the machine has been installed.

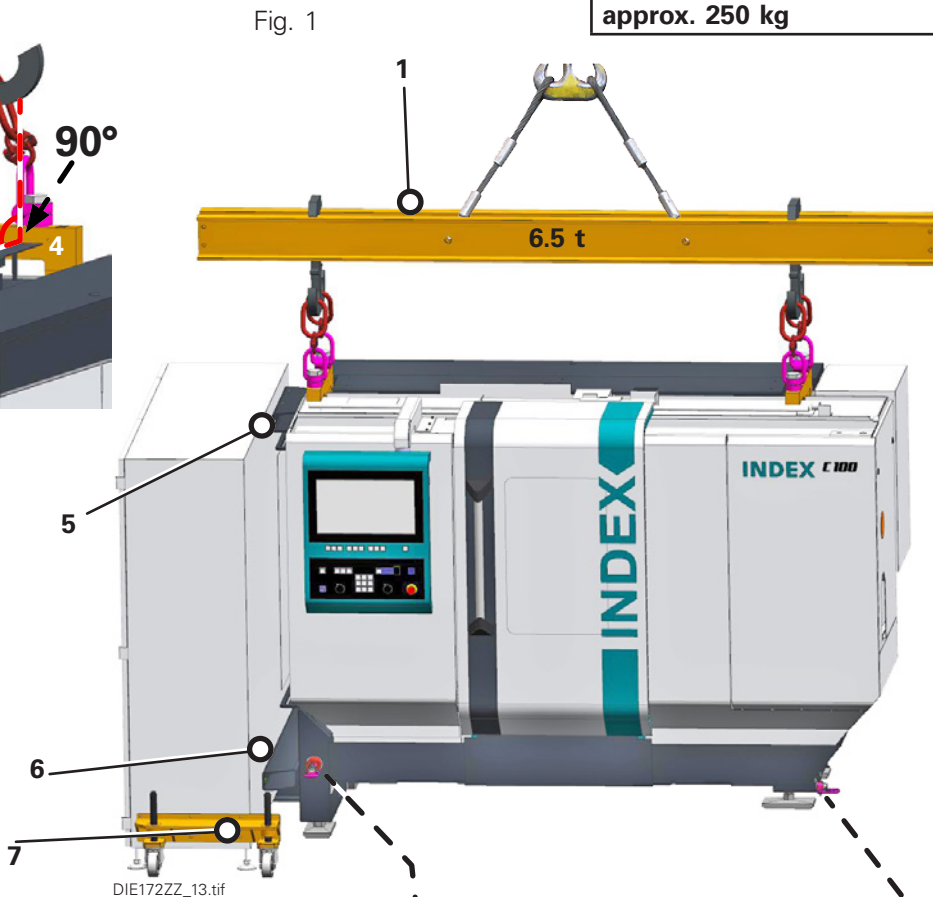

DIE172ZZ_13.tif

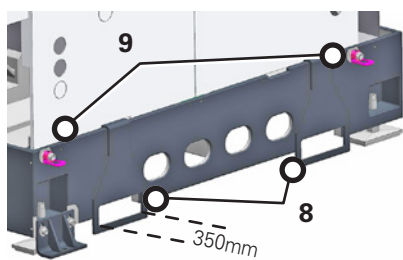

DIE172ZZ_15.tif

Fig. 3
View: Rear of machine

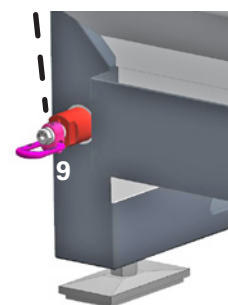

DIE172ZZ_16.tif

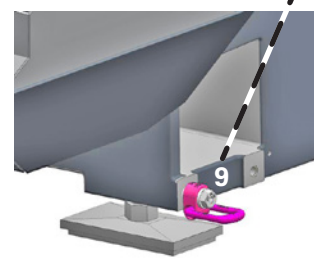

DIE172ZZ_17.tif

	Item	Qty.	Name	Part No.
Transport gear	1	1	Load beam 6.5t	10712743
	2	4	Oval suspension link	
	3	4	Chain connection link	
	4	2	Lifting bracket, 7t	
		4	+ load stand, M36, 7000 kg	
	6		Cyl. head screw 12.9 M16x140 4762	
	5	1	Upper transport carrier	
	6	1	Lower transport carrier	
	7	2	Transport bracket (control cabinet)	
	8	2	Transport lock (forklift transport)	
	9	4	Load stand, M16, 1500 kg	

DIE173EN - 2019-03-27

0319/SP/(Transport der Maschine)/20111137

Transport locks



All transport locks must be removed prior to machine start-up. Transport locks can be identified by their red color.

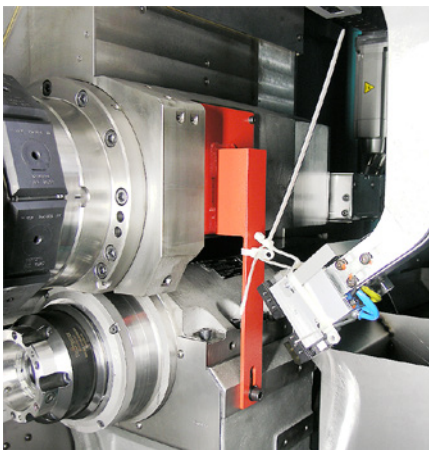

P1601.10042_25



P1601.10042_27

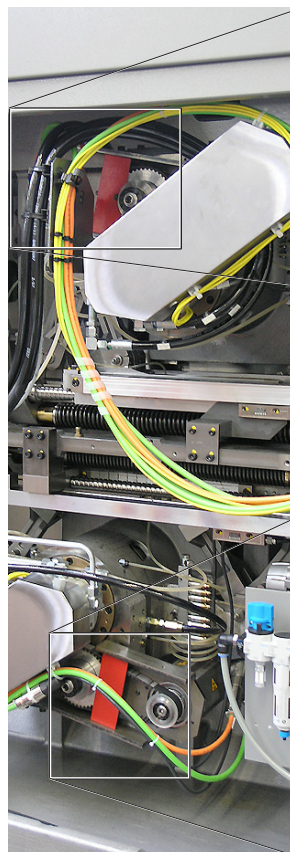

P1601.10042_28

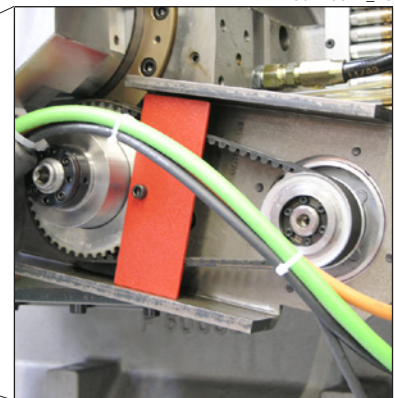

P1601.10042_26

Transport lock of the counter spindle without TC3

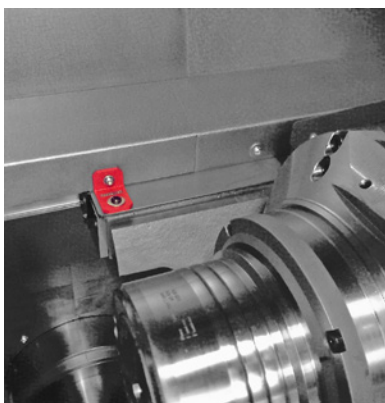

P1601.10042_47.tif

INDEX C200

Transporting the machine

INDEX

Kunde: _____

Projekt.-Nr.: _____ Masch. Nr.: _____

Machine mass
approx. 11400 kg

Transport gear
approx. 340 kg

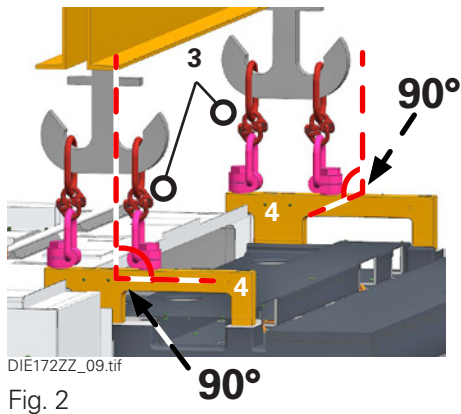

Caution!

Before lifting the machine, check the correct seat of the ropes/chains in the transport hooks and make sure that the hooks are engaged at the load beam (Fig.: 1 + 2) such that pulling at an angle is prevented.

If using transport ropes other than those specified herein, it is important to verify that those ropes do not contact the paneling and that the machine remains in a horizontal position (Fig. 1).

The load beam and the transport harness ropes required for the proper transport of the machine are generally supplied at a fee and can be returned to **INDEX-Werke** after the machine has been installed.

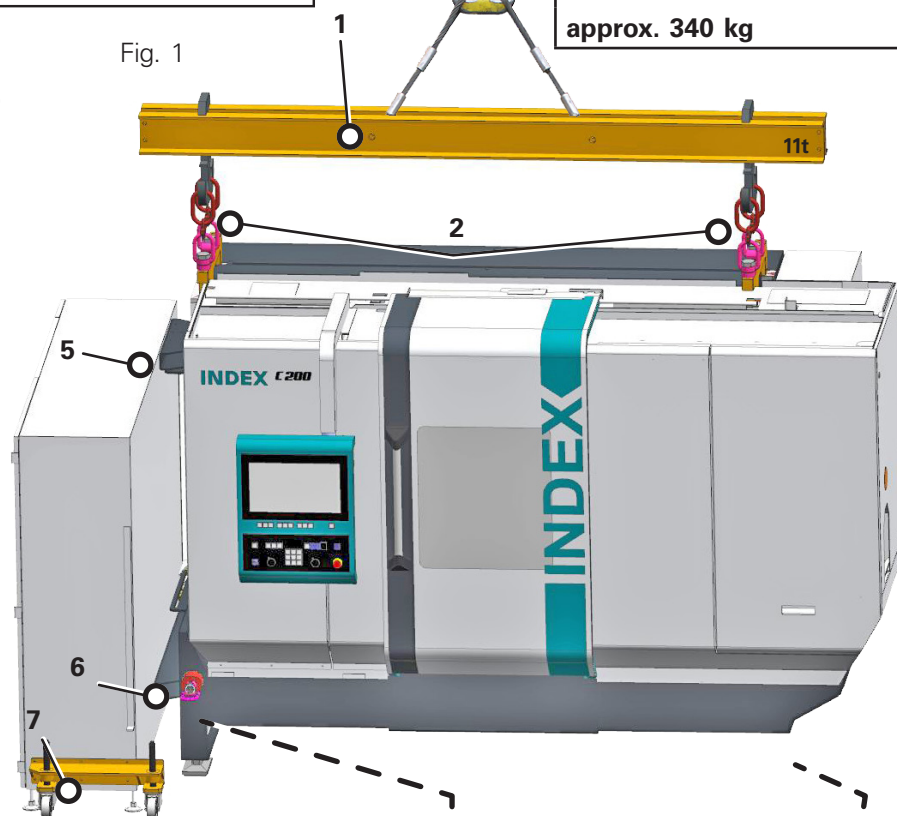

DIE172ZZ_08.tif

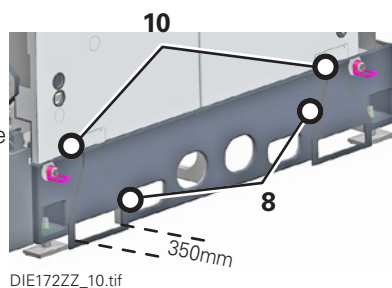
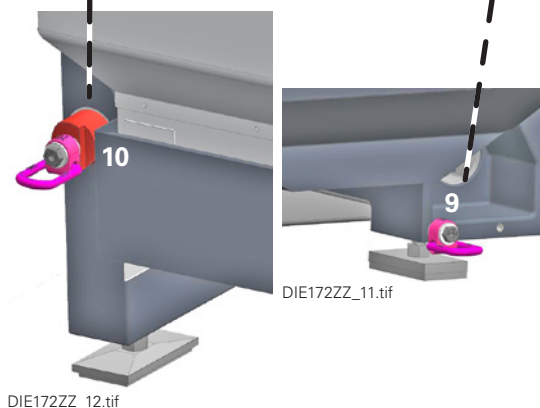

Fig. 3
View: Rear of machine



	Item	Qty.	Name	Part No.
Transport gear	1	1	Load beam 11t	10024717
	2	4	Oval suspension link	
	3	4	Chain connection link	
	4	2	Lifting bracket, 10 t	
		4	+ load stand, M36, 7000 kg	
	5	1	Upper transport carrier	
	6	1	Lower transport carrier	
	7	2	Transport bracket (control cabinet)	
	8	2	Transport lock (forklift transport)	
	9	1	Load stand, M16, 1500 kg	
	10	3	Load stand, M20, 2500 kg	

DIE174EN - 2019-03-27

0319/SP/(Transport der Maschine)/20111163

Transport locks



All transport locks must be removed prior to machine start-up. Transport locks can be identified by their red color.

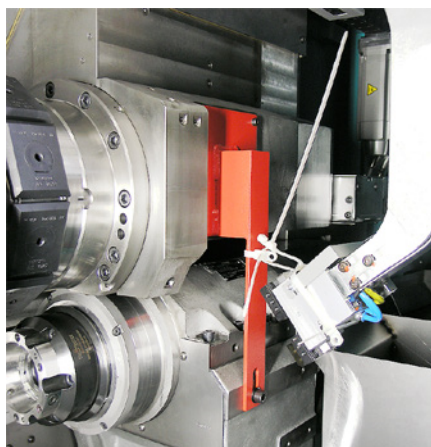

P1601.10042_25.tif



P1601.10042_36

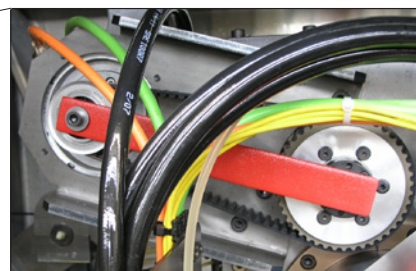

P1601.10042_39



P1601.10042_38

Transport lock of the counter spindle without TC3

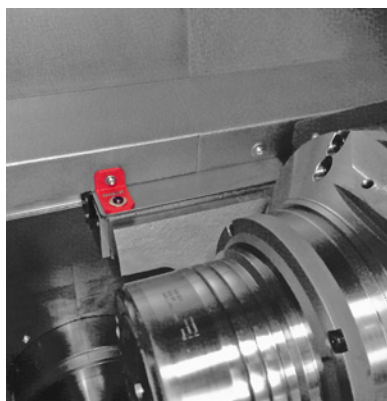

P1601.10042_47.tif

INDEX C200 – WHU

INDEX

Transporting the machine

Kunde: _____

Projekt.-Nr.: _____ Masch. Nr.: _____

Machine mass

approx. 12400 kg

Transport gear

approx. 340 kg

Caution!

Before lifting the machine, check the correct seat of the ropes/chains in the transport hooks and make sure that the hooks are engaged at the load beam (Fig.: 1 + 2) such that pulling at an angle is prevented. If using transport ropes other than those specified herein, it is important to verify that those ropes do not contact the paneling and that the machine remains in a horizontal position (Fig. 1).

The load beam and the transport harness ropes required for the proper transport of the machine are generally supplied at a fee and can be returned to **INDEX-Werke** after the machine has been installed.

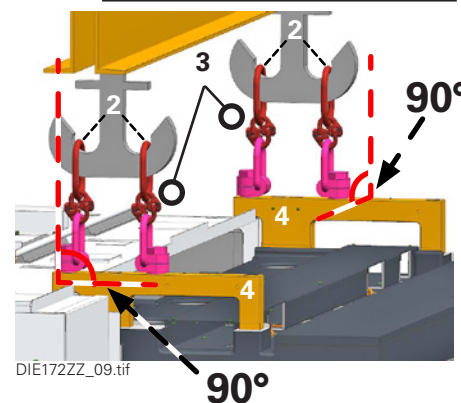

Fig. 1

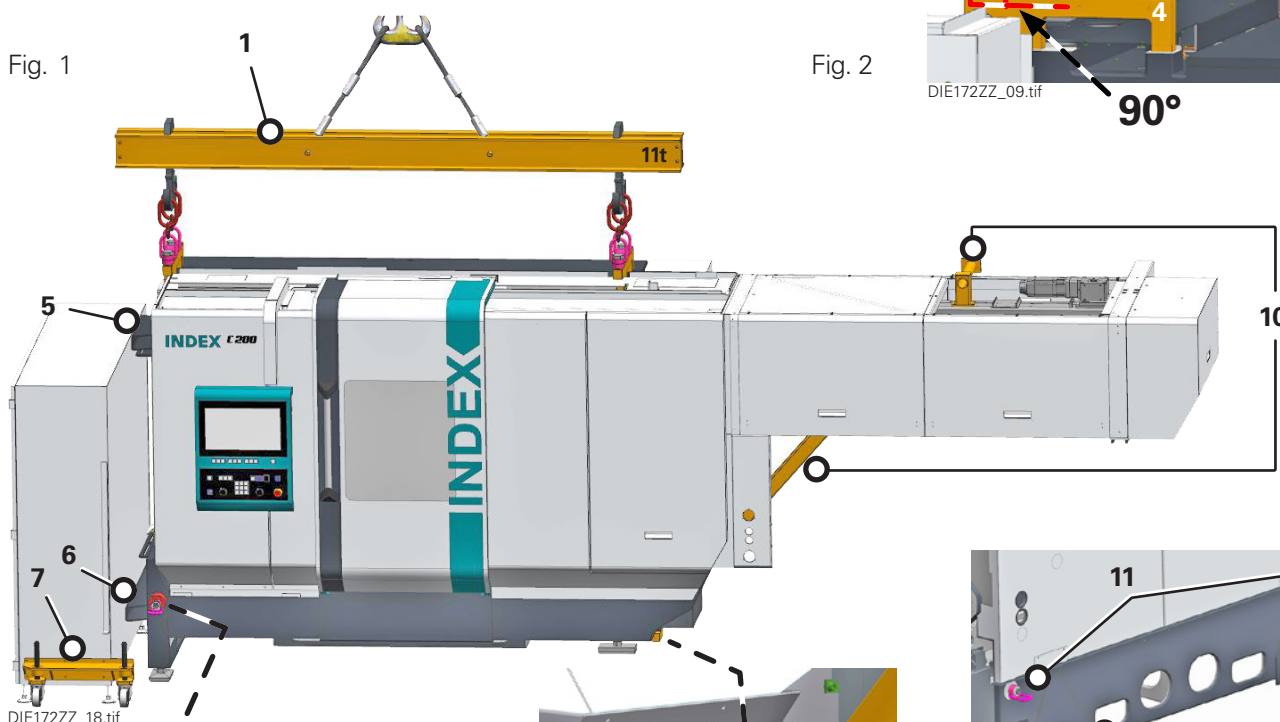

Fig. 2

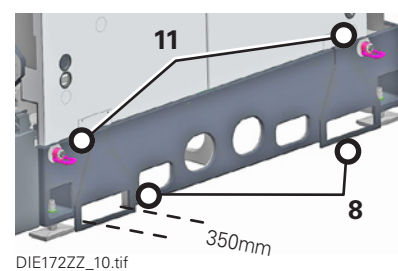
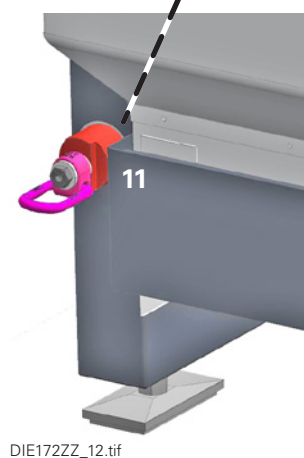

Fig. 3
View: Rear of machine



DIE172ZZ_19.tif

	Item	Qty.	Name	Part No.
Transport gear	1	1	Load beam 11t	10827108
	2	4	Oval suspension link	
	3	4	Chain connection link	
	4	2	Lifting bracket, 10 t	
	4	4	+ load stand, M36, 7000 kg	
	6	1	Cyl. head screw 12.9 M24x 90 4762 (630 Nm)	
	5	1	Upper transport carrier	
	6	1	Lower transport carrier	
	7	2	Transport bracket (control cabinet)	
	8	2	Transport lock (forklift transport)	
	9	1	Load stand, M16, 2000kg	
10	1	WHU support		
11	3	Load stand, M20, 3500kg		

DIE175EN - 2019-03-27

0319/SP/(Transport der Maschine)/20111186

WHU support



Before commissioning:

WHU supporting feet (Y-Fig.: 4) Reattach before commissioning.
The remove WHU transport support (X-Fig.: 4,5,6)

Preparation for new transport

First install the WHU transport support (X-Fig.: 4,5,6), then remove the actual WHU supporting feet (Y-Fig.: 4).

Fig. 4

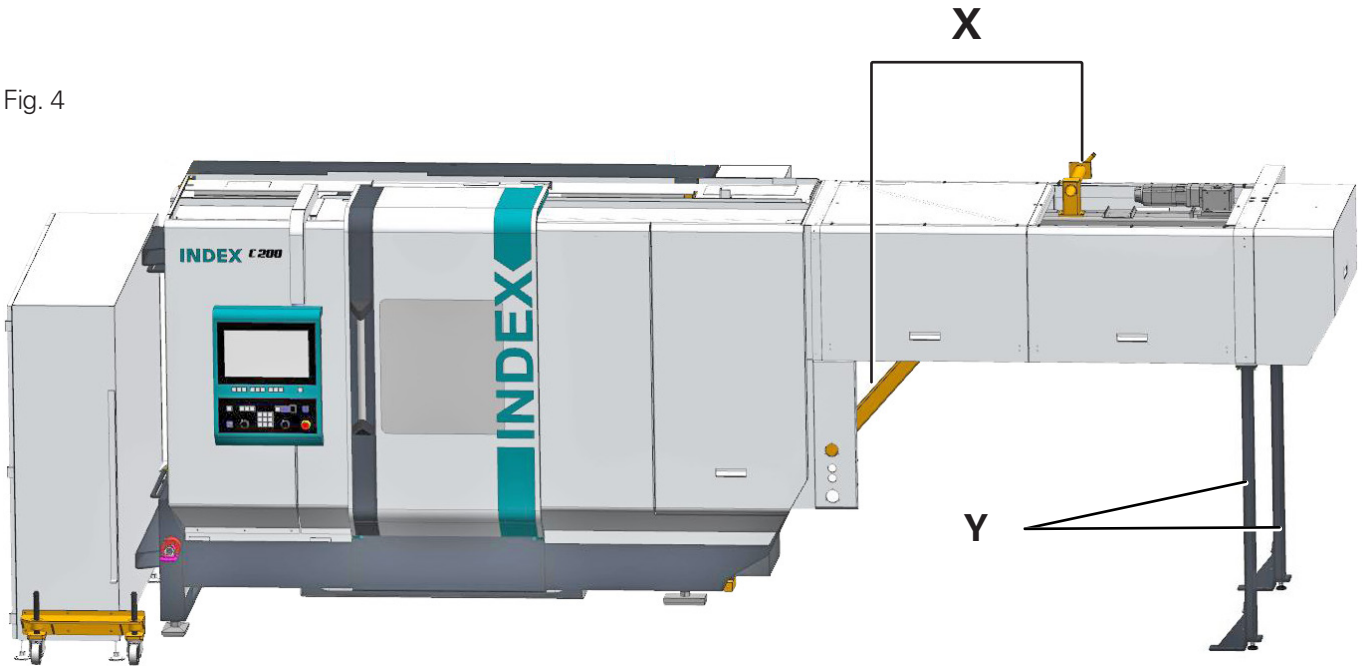

Fig. 5

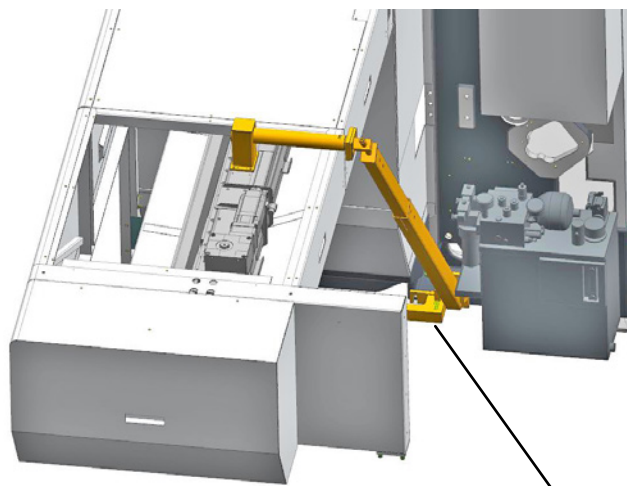
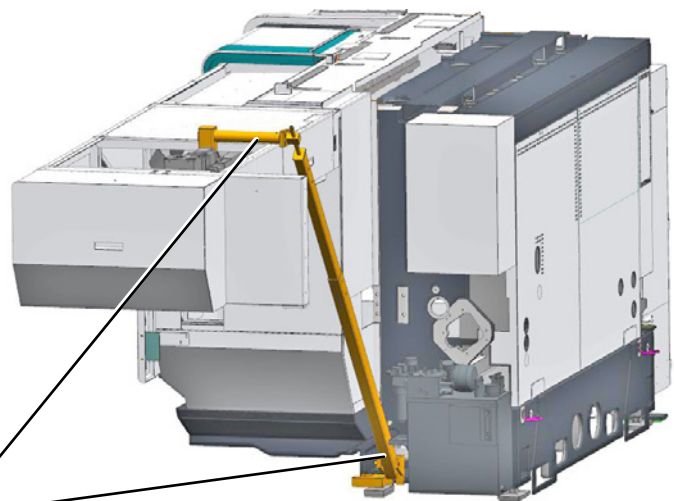

Fig. 6



DIE172ZZ_20.tif

DIE172ZZ_25.tif

X

Transport locks



All transport locks must be removed prior to machine start-up. Transport locks can be identified by their red color.

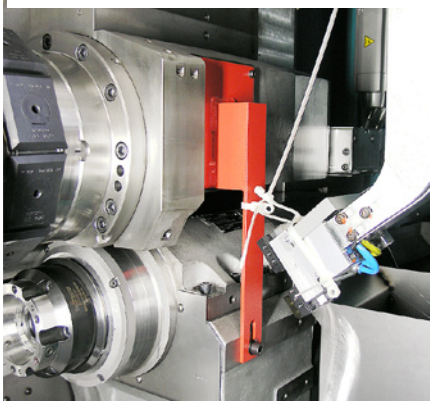

P1601.10042_25.tif



P1601.10042_36.tif



P1601.10042_39.tif



P1601.10042_38.tif

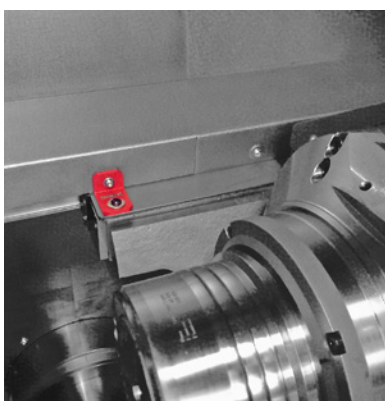

P1601.10042_47.tif

Transport lock of the counter spindle without TC3

Transport lock WHU Z5

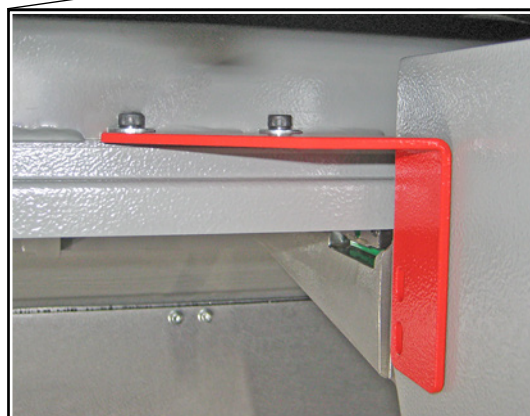

P2699.10021_05.tif

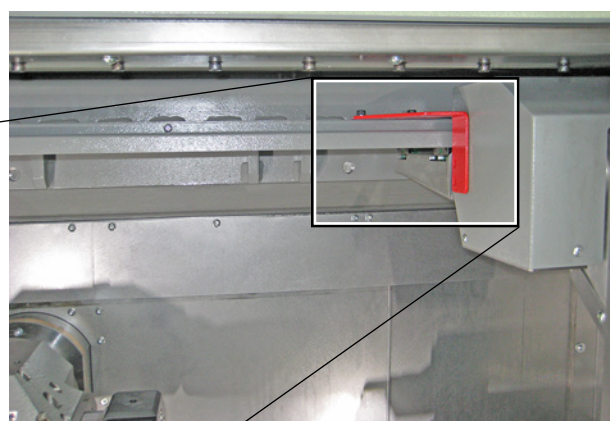

P2699.10021_04.tif

Transporting with Forklift

C100

The forklift should approach the machine from the rear. Observe the following when selecting the forklift:



Load distribution on the forklift:

Right fork	4900 kg
Left fork	1800 kg

Ensure a fork distance of 1300 mm.

Attach the transport tabs (1) required for transporting with a forklift (Fig.).

This prevents the machine from tilting on the transport forks.

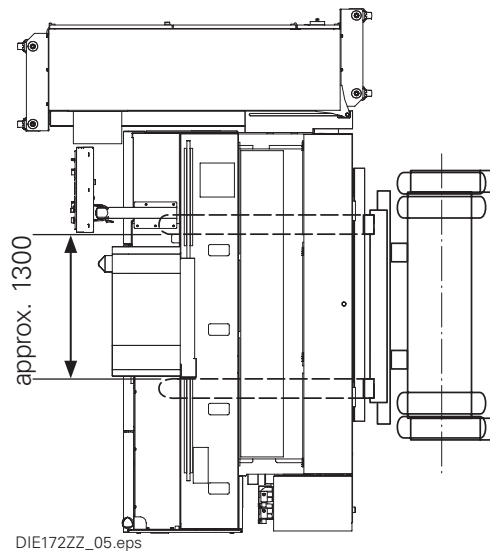
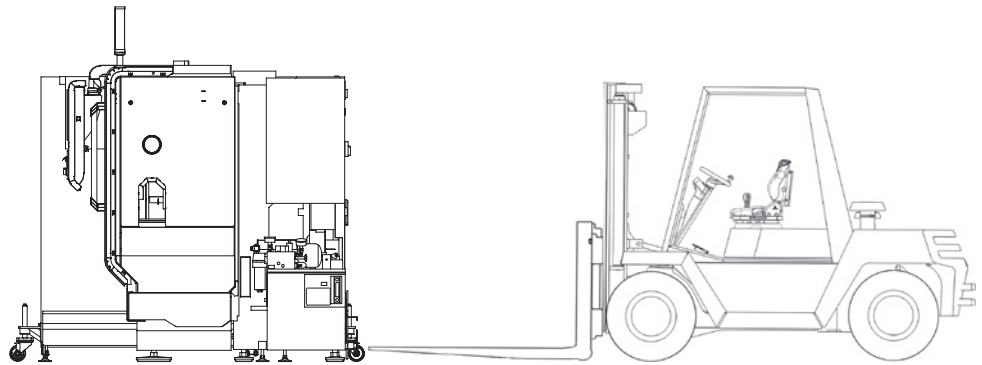

DIE172ZZ_05.eps

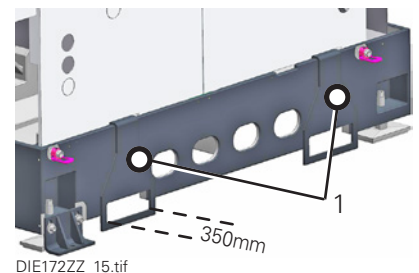

DIE172ZZ_15.tif

Transporting with Forklift

C200

The forklift should approach the machine from the rear. Observe the following when selecting the forklift:



Load distribution on the forklift:

Right fork	6500 kg
Left fork	3500 kg

Ensure a fork distance of 1400 mm.

Attach the transport tabs (1) required for transporting with a forklift (see Fig.).

This prevents the machine from tilting on the transport forks.

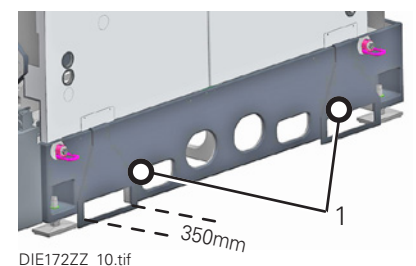
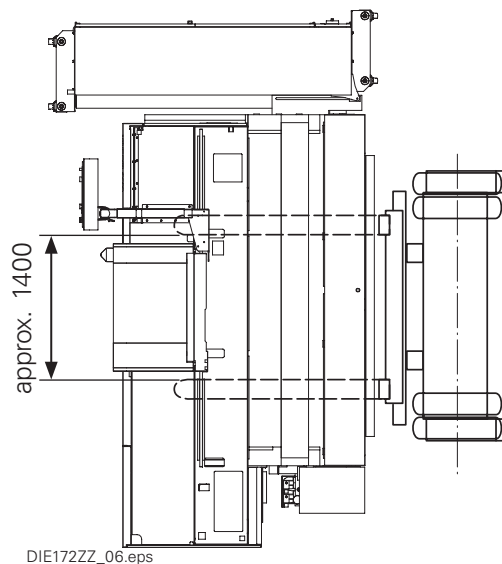
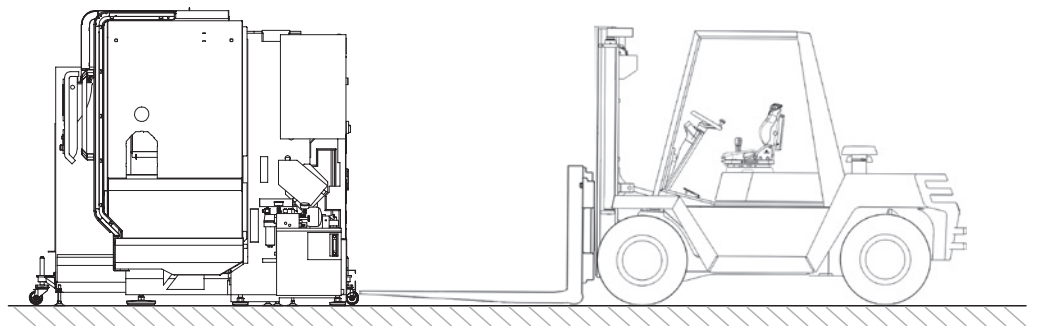

Transporting with casters

The use of transport casters is recommended only if cranes are not available at the installation site and the use of a mobile crane or forklift is not possible.

Transport casters have the advantage of a low loading height so that the machine can be loaded and unloaded using hydraulic jacks.

Disadvantages are, however, the relatively small wheels (casters), which require a solid, even floor of appropriate load capacity and very slow, smooth movements during the transport.

Depending on the size and mass of the machine, two or three transport casters are required for transport, one of which must be steerable.

The trolleys must always be parallel to the load to be lifted and in no case be oblique, because otherwise the casters would "rub out" causing the surfaces to be damaged by the load.



**Connect the steerable and fixed transport casters with steel cables (Fig.). This will prevent the casters from slipping when being pulling.
Secure the load with suitable straps.**

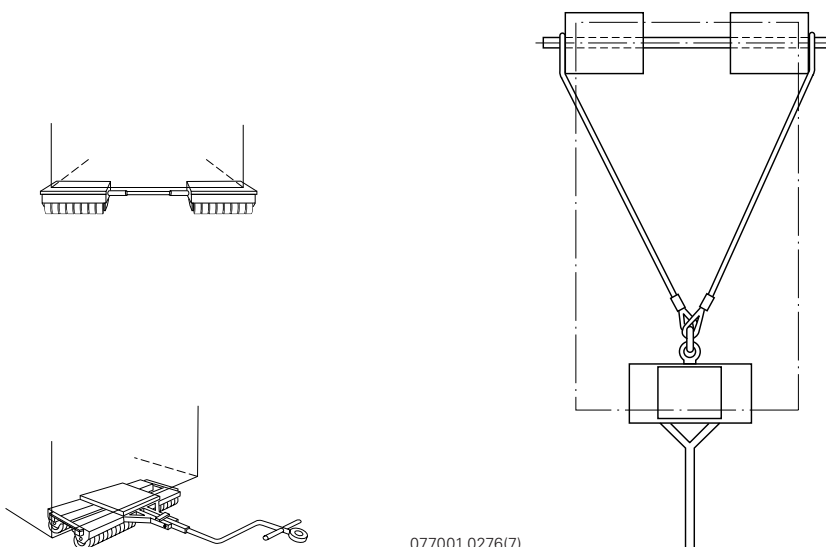

Notes on using hydraulic jacks for lifting:

- Always move the carrying section under the machine first, and then the steering section.
- For the carrying section, the support plates must always extend slightly beyond the edge of the transport load.
- Then the carrying section must be secured against rolling off.
- For the steering section, the transport load must be supported in the center of the turntable so that the steering bar can move freely.

Notes on using a crane for lifting:

- Lower the load carefully onto the carrying section.

C100

Transport casters

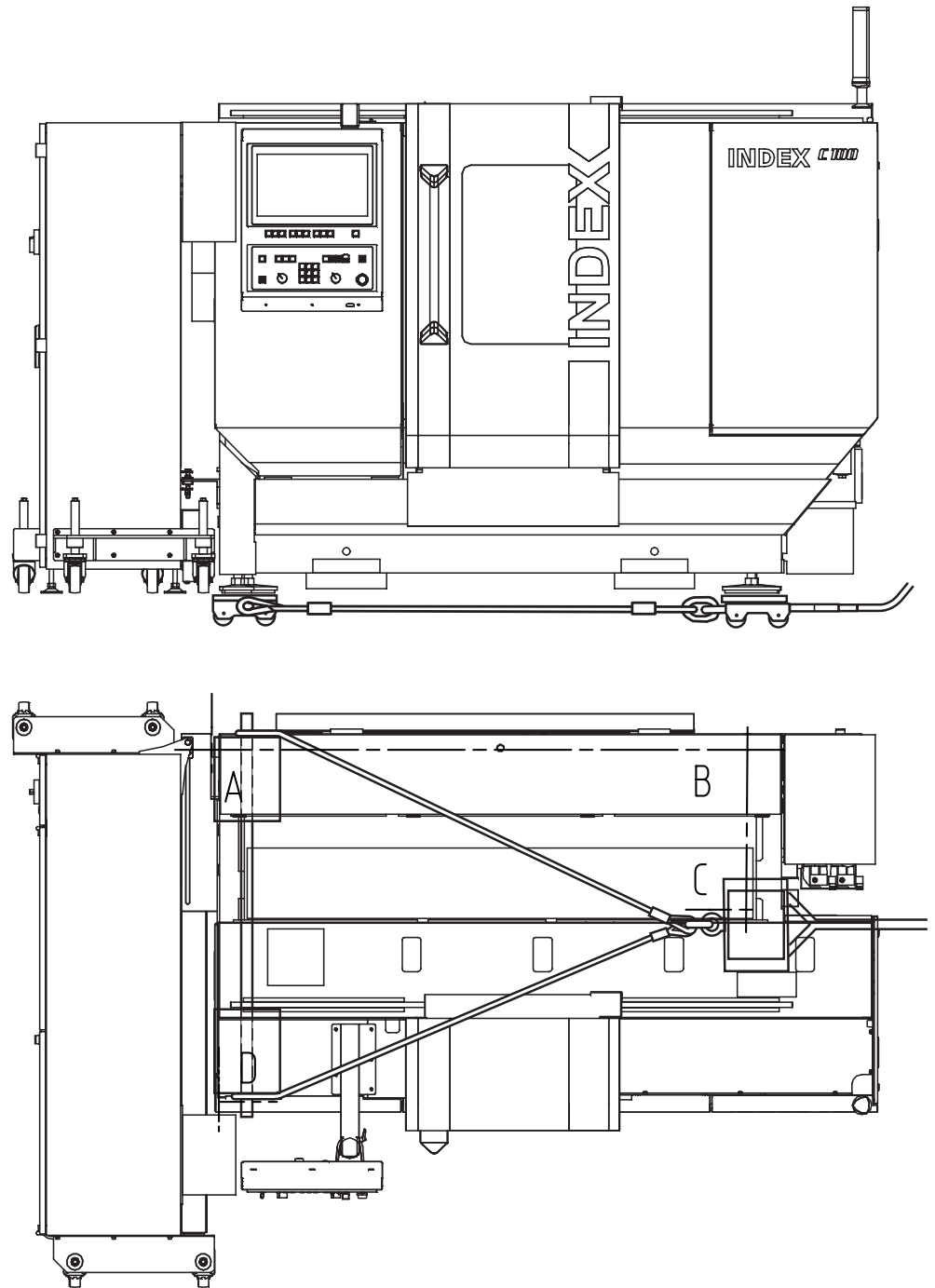

C200

Transport casters

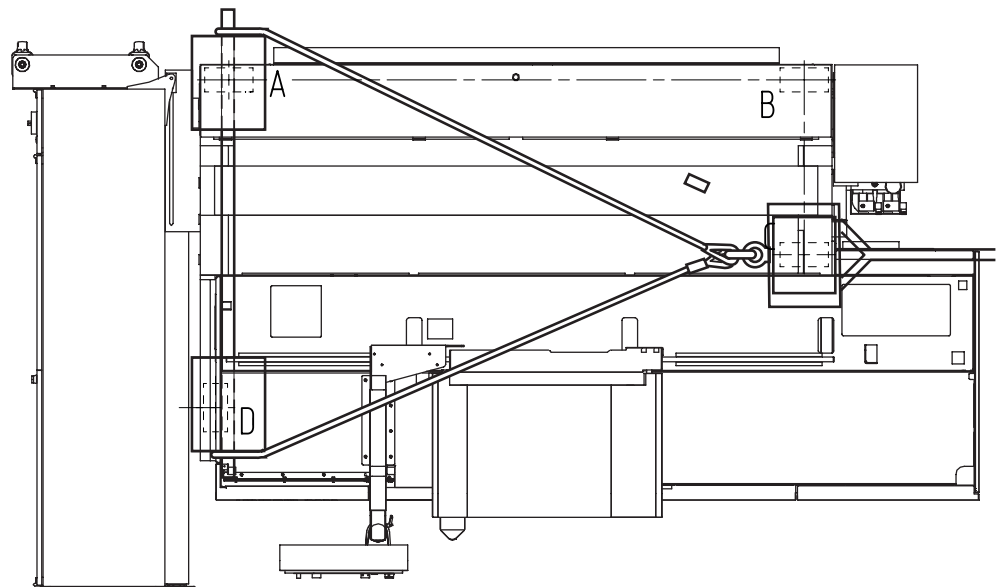
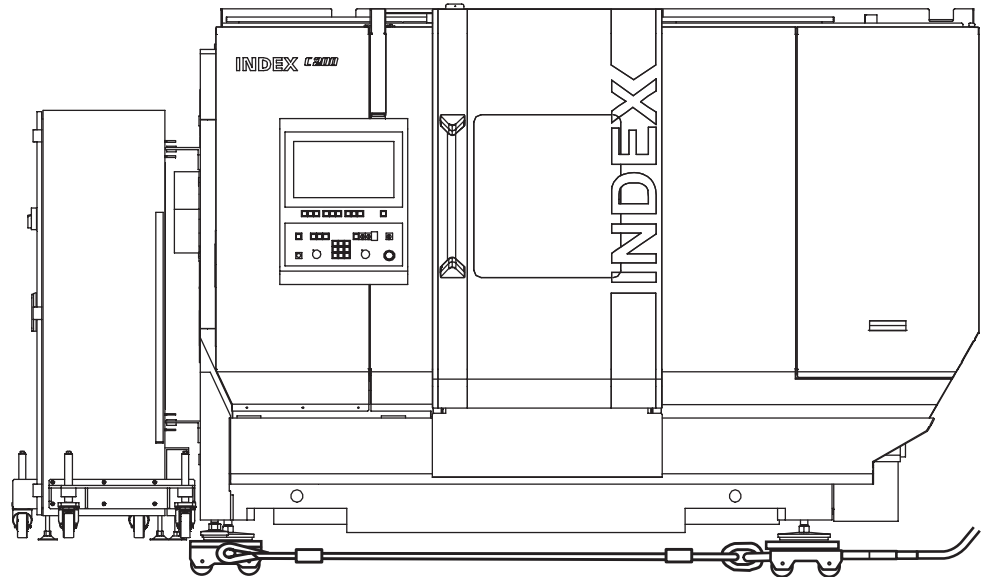

Lowering the Machine at the Installation Site

When the final location has been determined and properly prepared, the machine can be carefully moved and lowered there.

Lowering the machine ...

... with a crane or mobile crane

Lift the machine with a suitable crane slowly until it is suspended freely.

If the machine was moved to the installation site with a trolley or with transport casters, pull them out from under the machine.



Hydraulik-Heber von vorne.tif

... with hydraulic jacks (Figure)

Hydraulic jacks can be used if using a crane is not possible at the installation site.



Be sure to provide for a three-point support when lifting or lowering the machine with hydraulic jacks: two transport casters or supporting on the floor on one side, hydraulic jacks on the other side.

Always lift the machine with hydraulic jacks on one narrow side only. The other narrow side must rest on the transport means or on the floor.

Do not lift the machine more than absolutely necessary.

As the center of gravity is not in the center of the machine, if 2 hydraulic jacks are used, each hydraulic jack should have a minimum capacity of 1/3 of the machine mass.

If only one hydraulic jack is used, it should have a capacity of at least 2/3 of the machine mass.

Lift the machine incrementally and place wooden blocks underneath after each step. Use the same approach when lowering the machine.

If a forklift cannot be used for unloading, a transport means must be selected for the transport to the installation site whose loading height matches the lifting height of the hydraulic jacks.

We recommend to use transport casters in this case because they have a lower loading height.

Use only special machine hydraulic jacks with the following characteristics:

- The hydraulic jacks must have a sufficient capacity.
- The jacks must be stable and secured against tilting when lifting and lowering.
- The lifting load must not be able to slip off the jack.
- Sensitive and continuous lowering must be possible.
- The lifting load must not be damaged during lifting and lowering.

Installing the control cabinet



Before commissioning the machine, the control cabinet must be turned from the transport position to the working position.

Procedure:

- Attach the transport brackets (1) to the control cabinet.

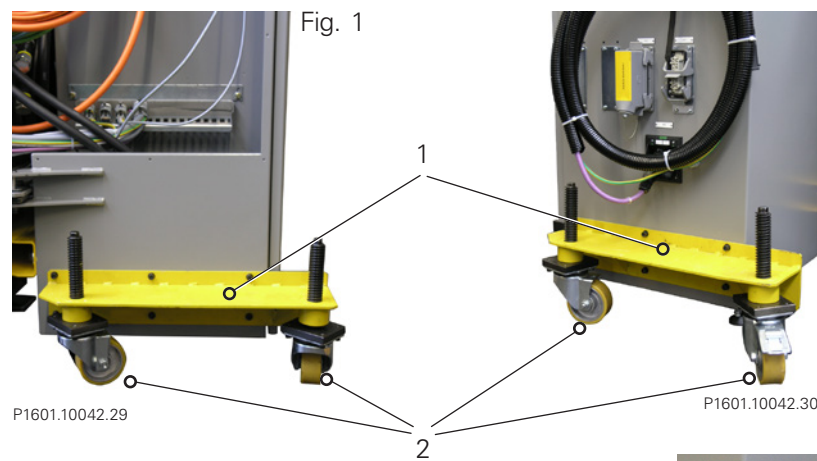

- Adjust the casters (2) of the transport device (1 in Fig. 1/2) to the ground with the threaded rods (3).

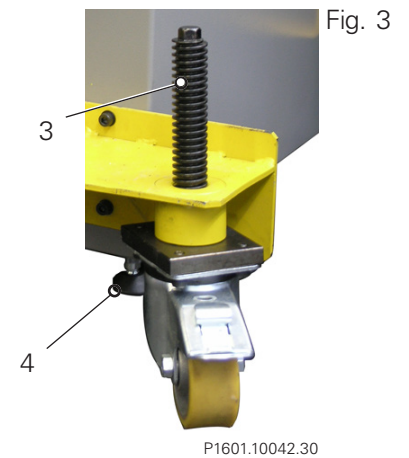



The control cabinet is attached twice to the top and bottom of the machine (Figs. 4 and 5).

- First loosen all four mounting screws (X in Fig. 4 and 5) and then remove them.

Fig. 4



X

Fig. 5

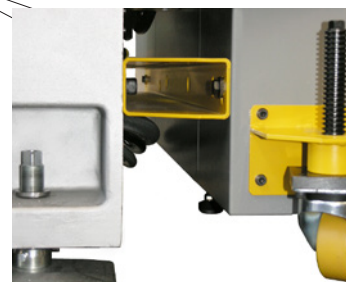

P1601.10042_10.tif

- Swivel the control cabinet to the working position (Fig. 6).

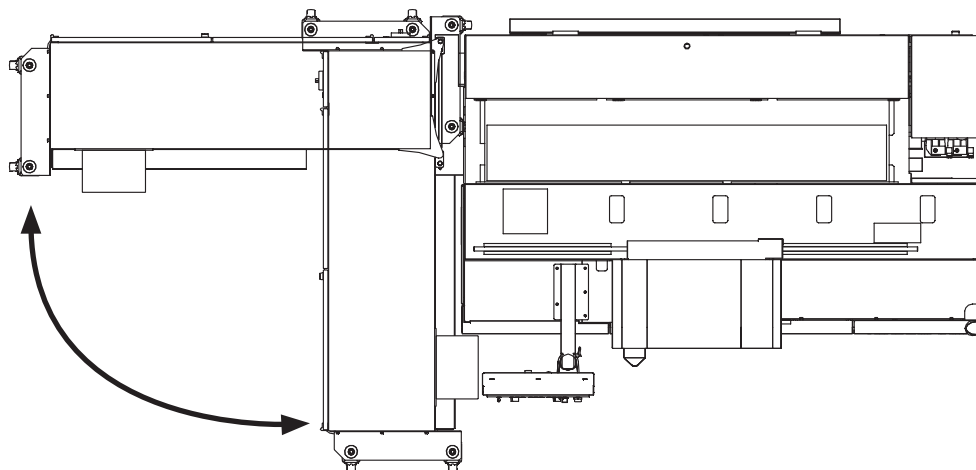

DIE172ZZ_07.eps

Fig. 6



After swiveling to the working position, place the control cabinet back on the leveling feet (4 in Fig. 3).

- Adjust the leveling feet (4 in Fig. 3) of the control cabinet to the floor.
- Remove the transport devices.

Unloading and transporting of separate units

Equipment options or accessories such as chip conveyors, bar feeders, bar loading magazines, etc. are separate units. They have dedicated transport regulations that must be observed for unloading and transporting (see the manufacturer's documentation).



Do not stand under suspended loads.

Minor separate units do not have specific transport regulations. They either rest on a pallet or are included in the packaging of another unit.

Use suitable transport ropes or straps for unloading and transporting.

Attach the transport ropes or straps making sure they cannot slip and the load is securely suspended.

Attach the ropes or straps to any eyebolts that are provided for transport.

Unpack the accessories and check them for completeness

After unloading, unpack the machine accessories and check them against the information on the delivery form for completeness (compare with bill of lading or delivery form).

In case of discrepancies, contact **INDEX** or your **INDEX** representative.

Installation

Electrical connection

Important notes



Caution! Danger of Life!

All work on the electrical equipment must be carried out exclusively by properly trained qualified personnel.



The control voltages are connected on one side with PE according to EN 60204-1. See the information on the wiring diagram.

The control cabinet may be opened only when the main switch is switched off. While the main switch is switched on, the control cabinet must be secured according to the valid safety standards.



See the order confirmation for the precise electrical requirements. The electrical specifications provided are decisive and binding. They must be available to **INDEX/TRAUB**'s customer service at any time.

The machine must be connected to the electrical supply network via the main switch (multi-wire cable). Be sure to observe the clockwise phase sequence for the connection.

The electrical connection is indicated in the wiring diagrams.

The machine is prepared for connection to three-phase power supplies (TN mains system).

Before connecting, check that the available line voltage matches the machine's operating voltage. If this is not the case, you will need an appropriate transformer connected in front of the machine.

Installing the machine

The C100/C200 machines are equipped with four adjustable feet as standard (see Fig. "Adjustable machine foot").



Screw in the machine foot (4) before lowering the machine onto the floor.

After placing down the machine, unscrew the control cabinet from the machine frame.

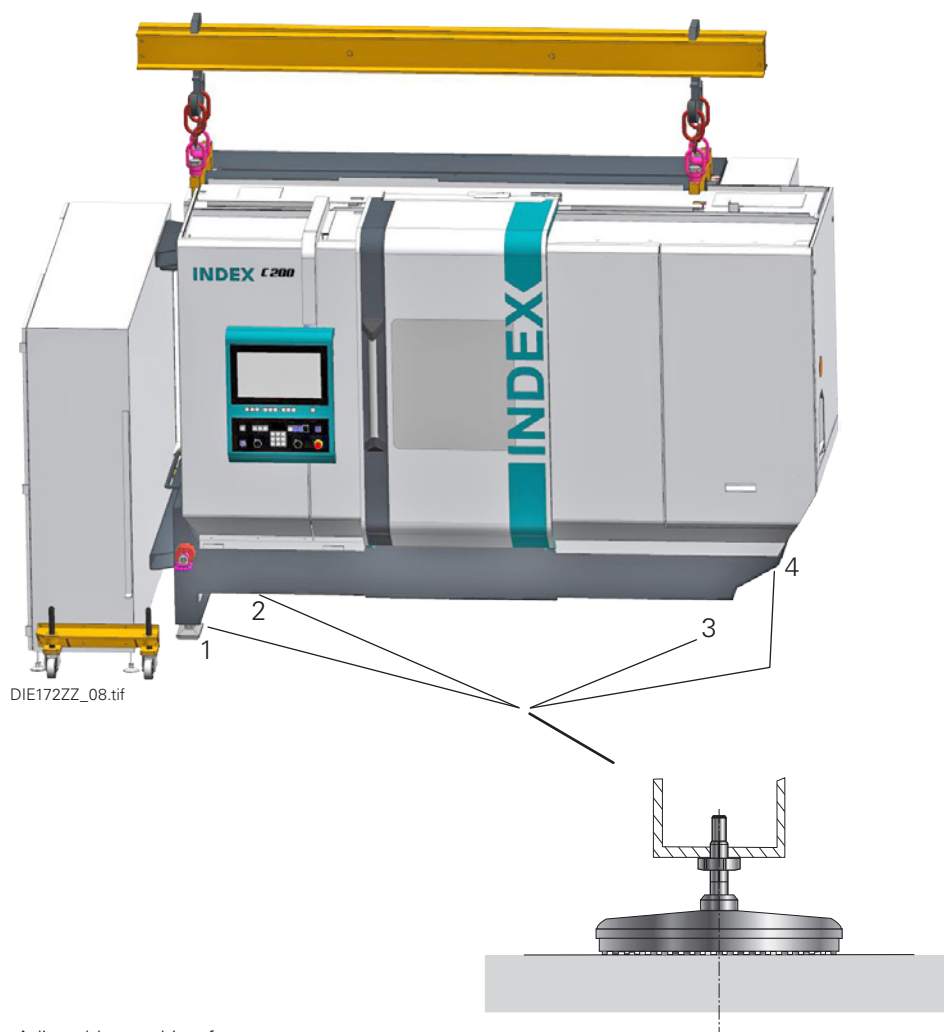

Fig.: Adjustable machine foot

P1601.10042_14.eps

Level the machine.

- Place the spirit levels (accuracy 0.02 mm/m) on the designated contact surfaces. Start with leveling in the Y axis. See Fig. "Leveling the overall machine".



The support surfaces for the spirit levels are the same as the screw-on surfaces of the lifting device for transporting the machine.

- Then level the machine in the Y direction using the machine feet (1) and (3) and spirit level 1.
- Next, turn spirit level 2 in the Z direction and align the machine in the Z direction with the aid of the machine foot (4).
- Then turn spirit level 2 in the Y direction and check again. (Repeat alignment operation, if necessary)
- Precision spirit levels 1 and 2 should be precisely leveled in the Y direction.



Slightly tighten machine foot (4).
(The machine position may not change by more than one division of the spirit level)

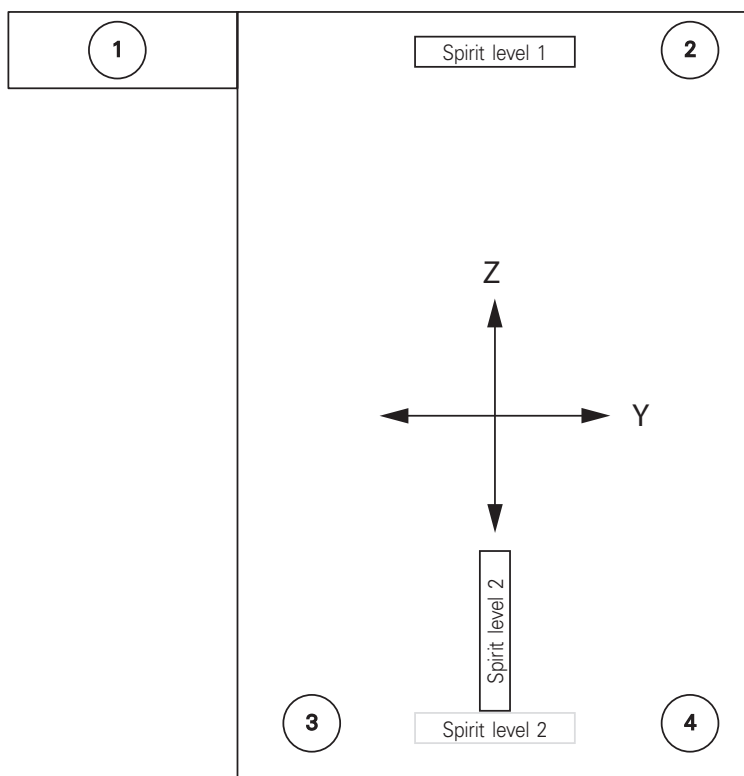

DIE172ZZ_08.eps

Fig. "Leveling the overall machine"

Installation and leveling of expansion stages and accessories

A bar feeder or bar loading magazine must be fastened to the machine using dowels. The dowels are included with the machine.

The bar guide, bar feeder or bar loading magazine have leveling elements that allow them to be aligned flush with the work spindle or spindle drum with ± 0.1 mm/m accuracy.

The workpiece conveyor belt, pallet station, etc. also have leveling elements that allow them to be aligned longitudinally and laterally to the main spindle rotating axis with ± 0.1 mm/m accuracy.

(For further information, see the corresponding installation plan in Chapter "Working Documents".)

Commissioning

This section lists all the actions that must be carried out in the order given before the machine is ready for start-up.

Only then the machine is ready for operation.

Cleaning the machine

All blank parts of the machine were treated by spray-covering with an anti-rust agent. Usually this protective cover is flushed away by the coolant during the operation of the machine.



To prevent solvent splashes from entering the eyes when cleaning the machine, be sure to wear suitable safety goggles. When cleaning the work area of the machine, protect your hands and arms by wearing long-sleeved clothing and suitable gloves. Risk of injury by sharp machine parts and cutting edges!

The anti-rust agent must be washed off, if the machine is put into operation only after a long time so that the protective layer has become very tough. The mounting surfaces for tool holders and accessories must also be cleaned. For this purpose, only solvents may be used that do not affect the machine paint. Suitable solutions are turpentine, petroleum or benzene.

Check the operating fluid levels and replenish, if necessary.

Hydraulic system: Fluid level check

Cooling lubricant unit: Replenish cooling lubricant

Central lubrication system: Fluid level check

Auxiliary equipment: Fluid level check



For information on the lubricating oil, hydraulic fluid and cooling lubricant grades, as well as on volumes and filling positions, see Chapter "Maintenance Regulations" and the machine installation plan in Chapter "Working Documents".

Pressure accumulator

If your machine was shipped by plane, all pressure accumulators attached to the machine are depressurized.

Before start-up of the machine, all pressure accumulators must be filled with nitrogen (N₂) by a specialist. The prescribed pressures must be observed.

For the prescribed pressures, see the hydraulic diagrams in Chapter "Working Documents".

Removing the Transport Locks



If the door to the work area is open, the door safety switch will remain open after disconnecting the power supply line.

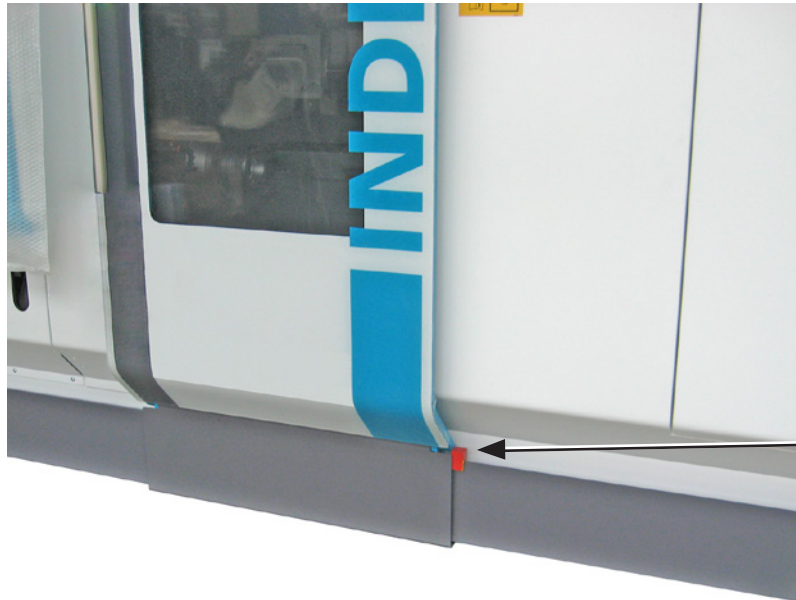

DIE172ZZ_30.tif

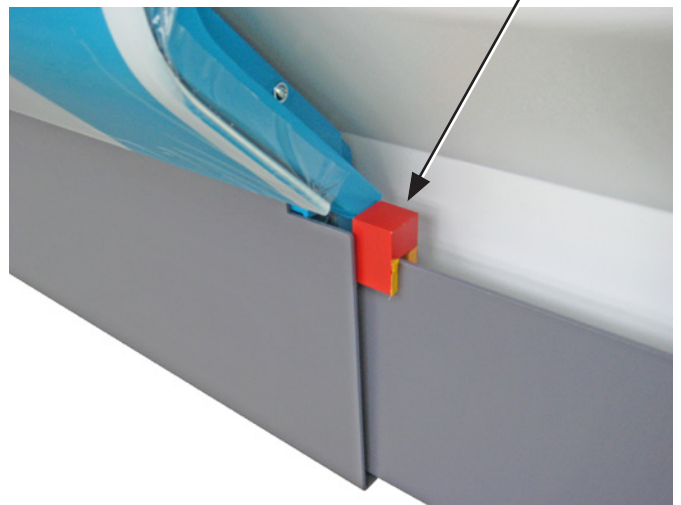

DIE172ZZ_31.tif

Fig.: Transport lock for work area door



Transport locks can be identified by their red color.

Remove all transport locks prior to machine start-up.
Store the removed transport locks at a safe place so they are available for another transport in the future.

Attaching Filling/Breathing Filter

For information, see the printed document "Important Notes Before Start-up".

Data loss due to prolonged downtime



The machine is functional only after all data have been entered.

After a prolonged downtime of the machine, data may be lost in the RAM. In such a case, the lost data must be re-entered or re-loaded before the machine can be put back into operation.

The data are recorded in the start-up report and backed up on a storage medium. The start-up report and the storage medium are located in the document pocket in the door of the control cabinet.

Switching on the machine

See Chapter "Operating the Machine".



Be sure to fill the cooling lubricant tank before switching on the machine. The cooling lubricant pump will be damaged by running dry.

Relocation



For transport by air, all pressure accumulators attached to the machine must be depressurized by a specialist.

Set the main switch to OFF and lock it against powering on. Depressurize the hydraulic system by opening the accumulator drain valve(s).

Provide for the transport gear appropriate for the machine. It can be ordered from **INDEX** by specifying the type and number of the machine.



Replace the filling and breathing filters with blanking plugs.

For information, see the printed document "Important Notes Before Start-up". Reverse the steps described there.

Only for machines equipped with chip conveyor

Unscrew the coolant hose from the screw connection above the coolant tank and loosen the power line connections to the chip conveyor's coolant motor and drive motor.

Pull out the chip conveyor and clean it.

Only for Machines Equipped With Bar Feeder or Bar Loading Magazine

Loosen the two hydraulic lines P and T to the bar feeder or bar loading magazine.

For the bar feeder, disconnect the connector of one power line; for the bar loading magazine, disconnect the connectors of three power lines.



**INDEX-Werke GmbH & Co. KG
Hahn & Tessky**

Plochinger Straße 92
D-73730 Esslingen

Fon +49 711 3191-0
Fax +49 711 3191-587

info@index-werke.de
www.index-werke.de